



The power and character of the legendary GM small block available in an industrial engine

Vortec 5.7L V-8 Industrial Engine

- High-flow cylinder head with straighter intake ports and a higher compression ratio delivers impressive horsepower
- Valvetrain features advanced design silent timing chain for added durability and positive inlet valve stem seals for reduced oil consumption
- Roller valve lifters for reduced friction and improved performance
- Composite front timing cover for noise reduction and corrosion protection
- Water pump features include:
 - Revised housing - a reservoir cavity replaces the weep hole
 - Upgraded shaft, bearing, and seal for extended life
 - Shrouded impeller for improved efficiency
- Cylinder head gaskets have stainless steel core for corrosion resistance



The Vortec 5.7L V-8 engine delivers excellent performance and durability for a variety of applications.

Available Options

- A fifth-generation electronic control module (MEFI-5) and related parts are available in kit form. The ECM uses state-of-the-art technology to optimize fuel spark requirements.
- Integral Air Fuel Module (IAFM) inlet manifold (gasoline only).
- EST and HEI distributors and coils are available in kit form.

Vortec 5.7L Feature Focus

GM Powertrain takes its expertise in designing outstanding Vortec truck and SUV engines and leverages it to make sophisticated yet extremely durable industrial engines. In addition, the well-recognized Vortec brand name by itself has become a valuable selling tool for OEMs.

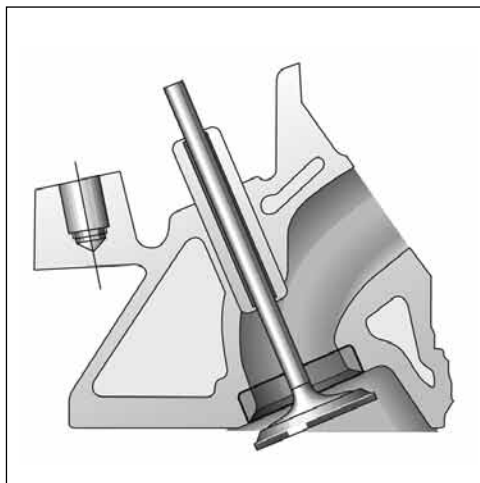

The exhaust valve seat inserts in the cylinder head provide superb durability.



All GM industrial engines are Vortec engines. Vortec means uncompromised power — outstanding power with no sacrifice in fuel efficiency or durability and very little required maintenance.

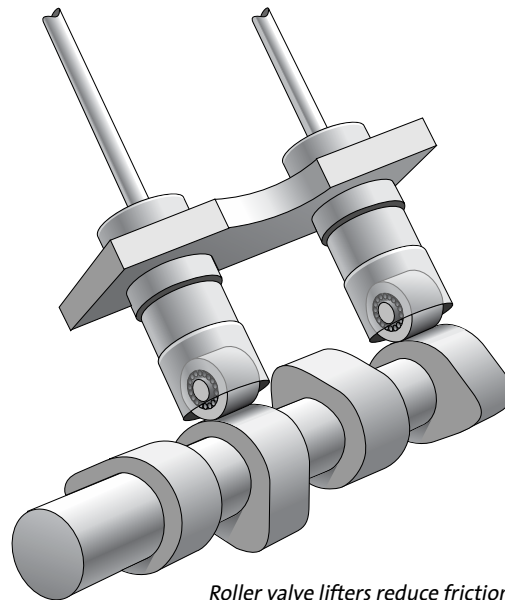

Roller valve lifters reduce friction and improve performance.

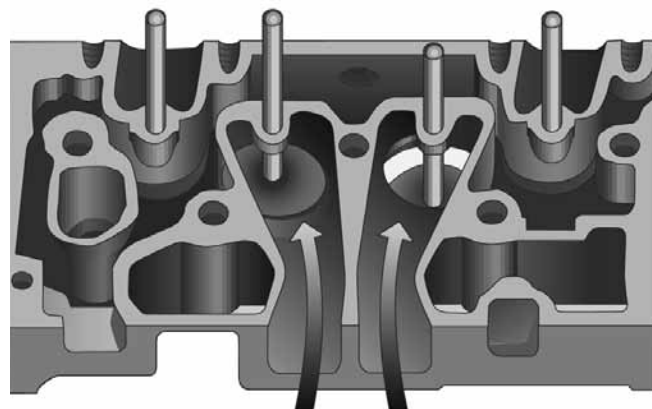

A high-flow cylinder head with straighter intake ports and a higher compression ratio delivers significantly better combustion for all fuels.

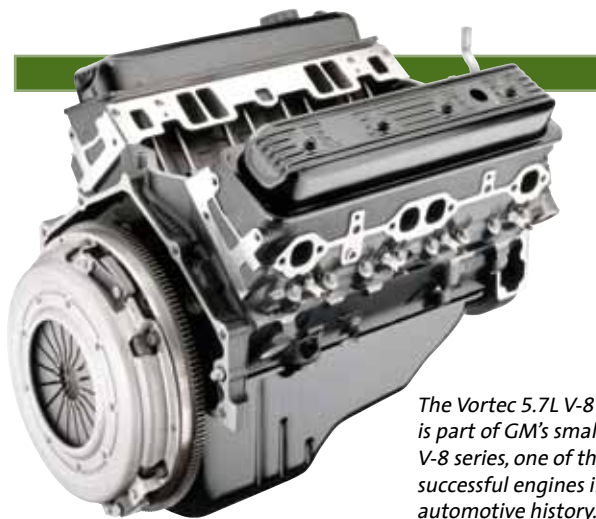

The Vortec 5.7L V-8 engine is part of GM's small block V-8 series, one of the most successful engines in automotive history.

Specifications

Type: 5.7L V-8 Gen 1e Small Block

Displacement: 350 cid (5736 cc)

Engine Orientation: Longitudinal

Compression Ratio: 9.4:1

Valve Configuration: Overhead Valves
(2 valves per cylinder)

Assembly Site: Toluca, Mexico

Valve Lifters: Hydraulic Roller

Firing Order: 1-8-4-3-6-5-7-2

Bore x Stroke: 101.60 x 88.39 mm

Bore Center: 111.76 mm

Bore Area: 648.59 cm²

Fuel System: None

Fuel Type: LP & CNG

Horsepower:

216 hp (161 kW) @ 4000 rpm (Propane)

196 hp (146 kW) @ 4000 rpm (Natural Gas)

Torque:

308 lb-ft (418 Nm) @ 1400 rpm (Propane)

283 lb-ft (384 Nm) @ 1600 rpm (Natural Gas)

Actual power levels may vary depending on OEM calibration and application.

Fuel Shutoff: N/A

Shipping Weight: 432 lb (196 kg)

Emissions Controls: Positive Crankcase Ventilation

Materials:

Block: Cast Iron GM232-M

Cylinder Head: Cast Iron

Intake Manifold: None

Exhaust Manifold: None

Main Bearing Caps: Cast Iron GM232-M

Crankshaft: Nodular Iron

Camshaft: 5150 Steel Billet

Connecting Rods: Forged - SAE 1141

Information may vary with application. All specifications listed are based on the latest product information available at the time of publication. The right is reserved to make changes at any time without notice.

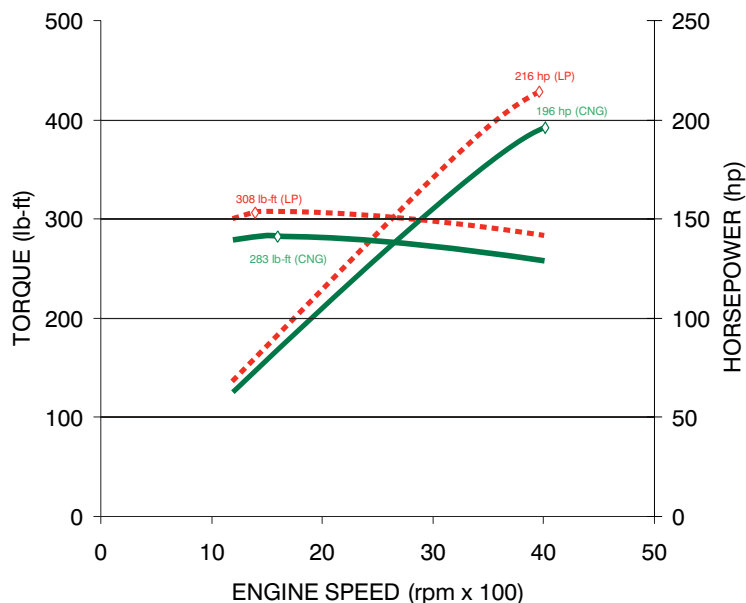

Actual power levels may vary depending on OEM calibration and application.

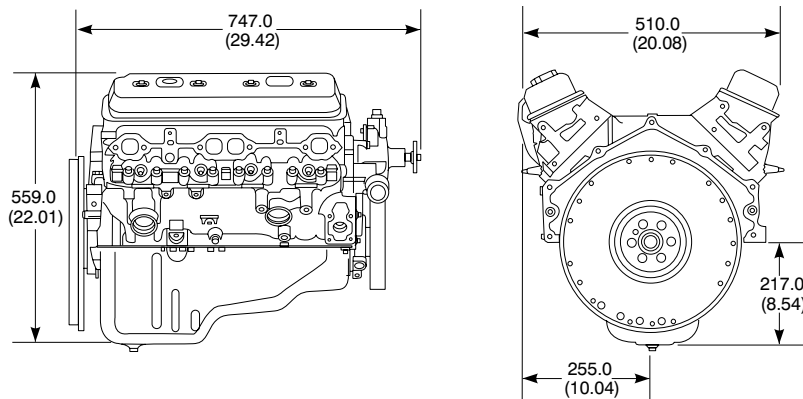

GM Powertrain

www.gmpowertrain.com